

**BEEZER**<sup>®</sup>  
a brand by ritter

The art  
of cooling.





accent line

**BEEZER**  
a brand by ritter

THE ART OF COOLING

# BEEZER®

## a brand by ritter

As a traditional Bavarian company, ritterwerk develops and manufactures high-quality table-top and built-in household appliances to make everyday kitchen tasks easier. Its range includes food slicers, toasters, kettles, hand blenders and built-in appliances.

In 2023, with the launch of BEEZER®, ritterwerk presented itself as an innovator in the field of rapid cooling for the first time: the world's fastest bottle cooler marked the beginning of this journey.

What began as a new product has become an independent brand offering sophisticated cooling solutions: BEEZER® – the art of cooling.

Alongside the beverage cooler, the BEEZER® IceBall and BEEZER® IceCube mini have been ensuring perfectly chilled drinks since 2026. Whether bottles or ice: BEEZER® brings cooling to the point – stylishly, spontaneously and impressively.

## Overview

---

**04-15** BEEZER® Beverage cooler

---

**16-23** BEEZER® IceBall

---

**24-31** BEEZER® IceCube mini

# The revolution among bottle coolers.

BEEZER® – probably the fastest, air-based beverage cooler in the world! Cold drinks in just a few minutes, without any annoying additional aids, for different bottle sizes. Designed in Germany.

Save space and energy in the fridge, enjoy cold drinks at the touch of a button and benefit from user-friendly handling. The BEEZER® beverage cooler is the innovative alternative to conventional bottle coolers and guarantees fast and precise cooling without the need for extra aids such as water or ice. With its special technology and unique cooling performance, it exceeds every expectation.

## Overview

---

**06-07** ADVANTAGES & USP

---

**08-09** DESIGN & OPERATION

---

**10-11** COOLING TIMES / SMART CONTROLS

---

**12-13** THE TECHNOLOGY

---

**14-15** PRODUCT DETAILS



**BEEZER**  
a brand by itteer

Worldwide patented technology

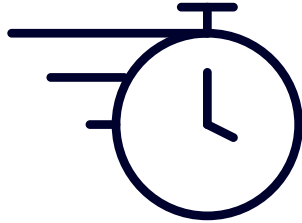

Fast and efficient



Dry cooling

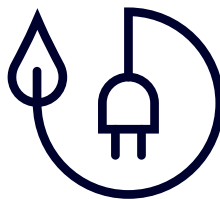

Energy saving

## DISTINCTION FROM OTHER COOLING METHODS

# The beverage cooler in comparison. **Clean, fast, and efficient.**

The BEEZER® beverage cooler is many times faster than cooling devices that use Peltier or thermoelectric systems. These devices are only suitable for maintaining the temperature of an already-cooled bottle, not for rapid cooling.

In contrast to methods and devices using ice water, salt, or other cooling agents, the BEEZER® beverage cooler cools with cold circulating air. The cooling process can therefore be repeated as often as desired. The technology ensures dry and clean cooling of beverages, which also prevents detached labels.



## and operation.

The settings on the beverage cooler are particularly user-friendly thanks to the intuitive user interface with its LED ring, display and just four buttons. This is how the BEEZER® beverage cooler works:

**1. Rotation:** The rotation function can be switched off by pressing the button, e.g. for square bottles or containers with sensitive labels or embossing.

**2. Container size:** Select the appropriate size – S 0.25 L / M 0.5 L / L 0.75 L

**3. Cooling level:** The three cooling levels are indicated on the display by one, two or three lines.

**4. WiFi symbol:** By simultaneously pressing the two lower buttons, the BEEZER® beverage cooler is paired with the app.

**1. Pre-cooling:** Just like an oven, the BEEZER® beverage cooler requires a one-time pre-cooling period of approx. 10 minutes after switching on.

**2. Insert beverage:** The beverage is inserted into the beverage coolers cooling chamber by opening the door.

**3. Configuration:** Select rotation, desired container size and cooling level.

**4. Start:** The BEEZER® beverage cooler starts cooling at the touch of this button. After 3 – 6 minutes, the beverage reaches the optimum drinking temperature.

---

ROTATION

---

---

COOLING LEVEL

---

---

WIFI SYMBOL

---

---

START BUTTON

---

---

ROTATION ON/OFF

---

---

CONTAINER SIZE

---

---

COOLING LEVEL

---



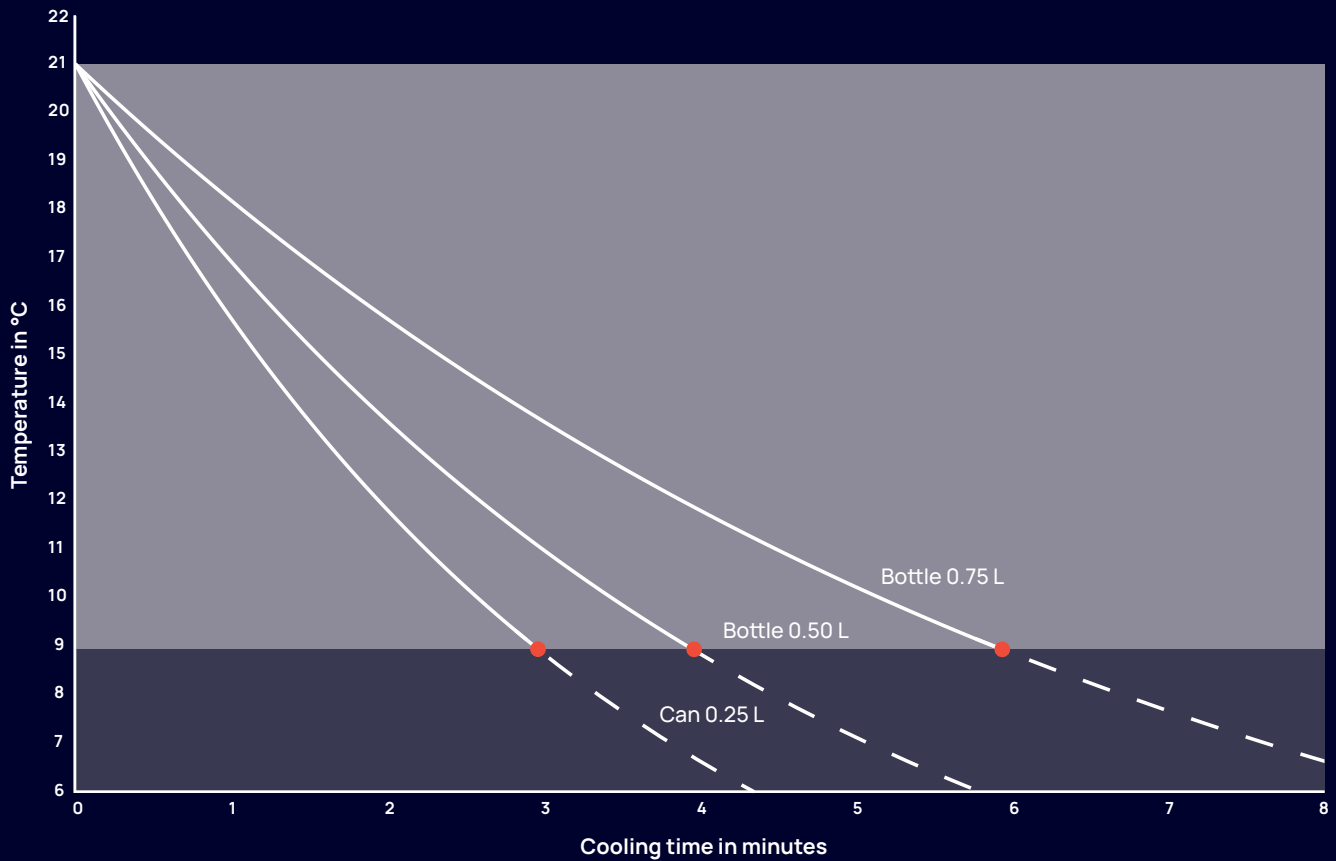

6

minutes for 0.75 L

3

minutes for 0.25 L

#### INCOMPARABLY FAST BEVERAGE COOLING

Long wait times are a thing of the past! The BEEZER® beverage cooler cools drinks from room temperature to an optimal drinking temperature of approx. 9°C within 3-6 minutes – a temperature difference of 12°C. The cooling time can be easily extended in order to obtain ice-cold drinks.

Neither a freezer nor a refrigerator is this fast, as they need 10x and 20x as long respectively for cooling. You not only save a lot of space, but also energy. „On-demand“ cooling only consumes electricity when cooling is actually being done. How energy-efficient the BEEZER® beverage cooler is compared to a wine refrigerator and how much energy is really saved can be easily determined with the consumption calculator on our homepage.

SMART CONTROL ALSO VIA APP

## Precise control settings thanks to BEEZER® Connect.

The BEEZER® beverage cooler offers numerous functions that can be controlled via the app. One of its practical functions is being able to switch on the appliance from anywhere on the go. This allows you to power up the beverage cooler and avoid waiting during the pre-cooling period. BEEZER® Connect also provides an overview of the most important parameters by displaying live information about the current mode, remaining cooling time and temperature in the cooling chamber.

The **expert mode** helps to determine the ideal cooling time for the desired temperature. Parameters such as initial temperature, volume, material and rotation can be entered and cooling can be started directly via the app. You can select your preferred cooling times and rotations with the **individual timer** and also start the cooling process directly via the app.

The **LED ring can be used as ambient lighting** in a variety of colours when the unit is switched off. The **temperature guide** ensures that you can always keep an eye on the ideal drinking temperature of your favourite drinks. Additionally, the beverage cooler **presets** can be easily changed via the app and the device saves the preferences.

**Further settings**, such as switching the beep on and off, make the BEEZER® beverage cooler even more user-friendly. This wide range of functions make the beverage cooler an indispensable device for anyone who wants to cool their beverages quickly and efficiently.



### 01 AIR CIRCULATION SYSTEM

The air circulating system with two radial fans ensures a constant flow to the bottle.

### 02 BOTTLE ROTATION

The shaft inside the cooling chamber rotates the bottles during the cooling process.



### 03 COOLING CIRCUIT

The key component is the compressor, which is also used in refrigerators.

### 04 INSULATION

The insulation of the cooling chamber ensures energy-efficient operation even in standby mode.

## The technology – here's how it works.

The technology is based on a specially developed process. Which is patented worldwide. It is based on a circulating air system in which air temperatures of below  $-30^{\circ}\text{C}$  are achieved in combination with the compressor circuit used.

After the pre-cooling phase of approx. 10 minutes, the unit is ready for use and the first bottle can be cooled. Once the bottle has been placed in the cooling chamber and the door has been closed, the cooling process begins.

Extremely cold air flows around the bottle at high speed, removing the heat energy contained in the bottle and the liquid. The bottle is rotated around its longitudinal axis during the cooling process in order to cool the liquid inside the bottle evenly and to increase the cooling speed.

### **Dry cooling without the use of additional aids**

In contrast to other devices that are also used to cool individual bottles, the BEEZER® beverage cooler does not require any additional aids such as water or ice cubes, which makes for a clean, dry and, above all, repeatable cooling process. Overall, the BEEZER® beverage cooler is also characterised by the fact that the cooling process can be carried out repeatedly. Several bottles can be cooled consecutively.

## among bottle coolers.

- Patented technology
- Cold drinks at the touch of a button at least 10x faster than a freezer
- Tabletop appliance with a cooling chamber for cans and bottles
- Efficient „on-demand“ cooling with compressor cooling
- Dry and clean cooling without water, ice or other aids
- The rated power is at a room temperature between 16 and 32 °C
- Intuitive user interface
- High-quality finish
- Simple operation via BEEZER® Connect

### TECHNICAL DATA

- Efficient compressor cooling with recirculating air circuit
- Refrigerant R290
- Climate class SN, N, ST, T
- 220-240 V, 276 W
- 50 Hz, 1.3 A
- SGS/GS seal, protection class 1, CE
- Maximum bottle size: Length 360 mm,  $\varnothing$  95 mm
- Dimensions: Width 25.5 cm  $\times$  Height 44.0 cm  $\times$  Depth 48.5 cm
- Weight: 23.0 kg

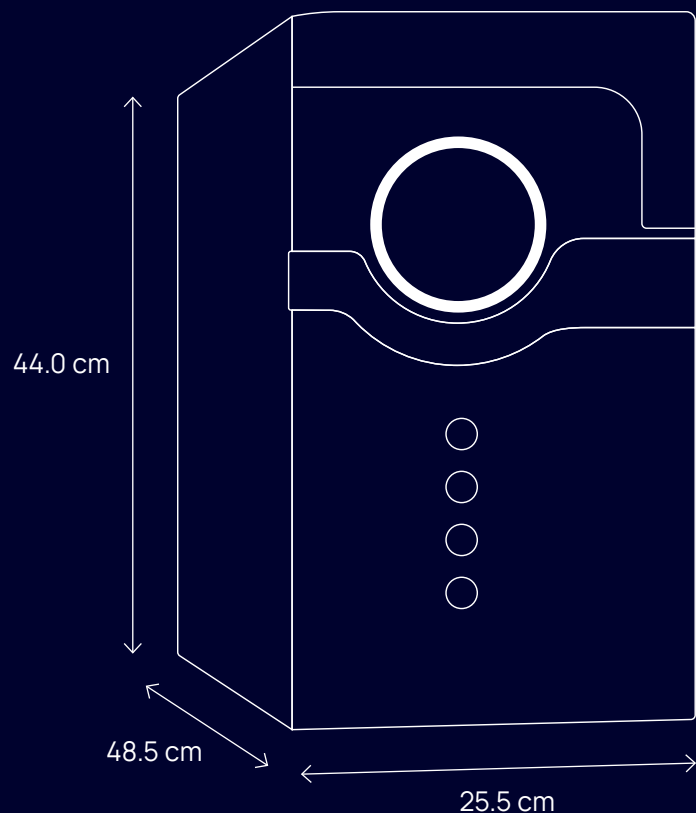



ITEM-NO. 950.001 / 40 04822 95001 3

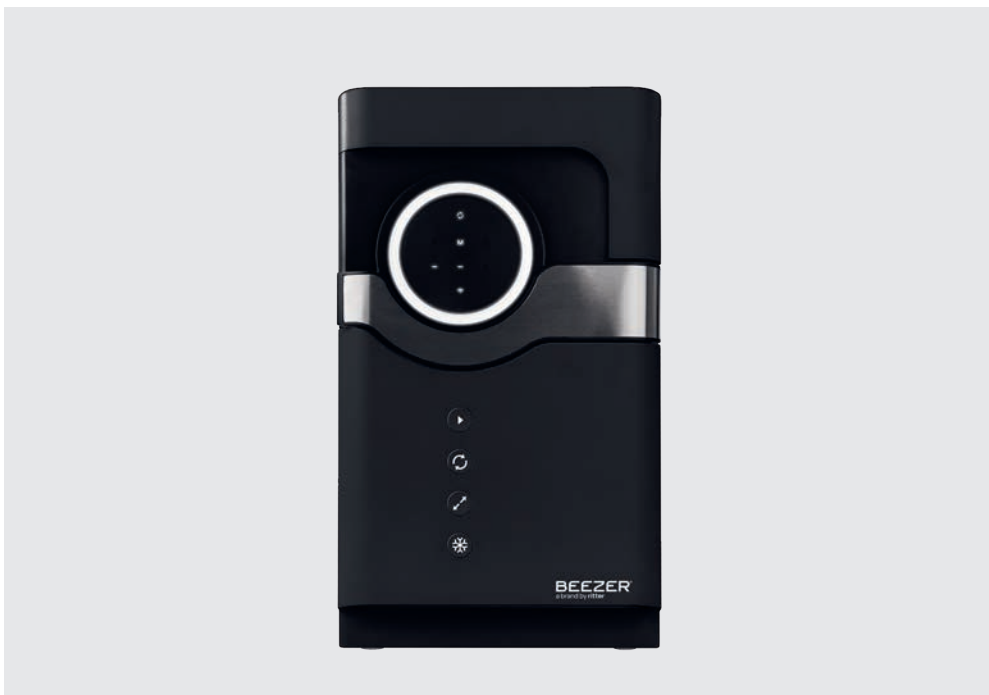

ITEM-NO. 950.000 / 40 04822 95000 6



reddot winner 2025

ENJOY IT ICE-COLD

# **BEEZER® IceBall**

## Crystal clear perfection.

The BEEZER® IceBall brings perfect ice to every kitchen, bar or event location: crystal clear, solid and exceptional.

Special moments often begin with a glass – and what's inside it. This clear Ice Ball melts slowly without watering down the taste of your drink. The drink stays pure. The moment remains special.

With the BEEZER® IceBall, ice becomes an experience. Solid and crystal clear, these Ice Balls are sure to impress. Not just visually. They offer real added value: they melt slowly, look great and are always ready when guests or enjoyment call.

## **Overview**

---

ADVANTAGES & USP

---

**20-21** DESIGN & OPERATION

---

**22-23** TECHNOLOGY & PRODUCT DETAILS



ICEMAKING

**BEEZER**  
a brand by ritter

Ice Balls are sure to impress

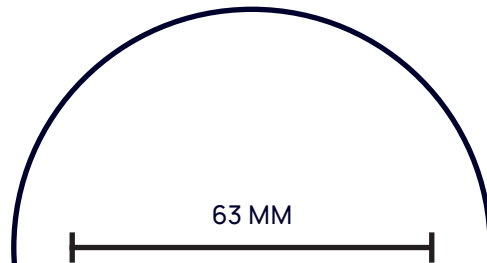

Crystal clear ice



50 MIN

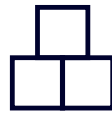

9 MIN

Extra slow melting

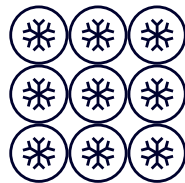

Large capacity

BEEZER® IceBall

## Crystal clear. Solid. Extraordinary.

The BEEZER® IceBall redefines ice with its perfect 63 mm Ice Balls, produced in just 90 minutes, which impress with their crystal clear, solid structure. They melt significantly slower than conventional ice cubes, ensuring maximum enjoyment without watering down your drink.

Thanks to its automatic self-cleaning function, the device remains hygienic and easy to maintain, making it ideal for daily use. With a 1.8-litre water tank, space for up to nine Ice Balls, and a clever water level warning, the BEEZER® IceBall is ready for any occasion.

The combination of precise aluminum mold, energy-saving R290 compressor and intuitive operation makes the BEEZER® IceBall the perfect addition to any kitchen, bar or upcoming event.



# Simple function and operation.

The BEEZER® IceBall is as easy to use as it is efficient. All functions can be controlled quickly and conveniently via the user-friendly interface, which features a clear display and an illuminated LED ring. Clear symbols and essential menu navigation enable simple and safe handling.

**On/Off button:** The IceBall starts at the touch of a button, automatically initiating both the device and the production process for crystal-clear Ice Balls. The first Ice Balls are ready after around 90 minutes.

**Eject Ice Balls:** If Ice Balls are needed in the meantime, the current production process can be interrupted at any time by pressing the button. The ejected Ice Balls are pre-formed but not yet fully filled.

**Cleaning:** The integrated self-cleaning function is particularly convenient. It ensures hygienic cleanliness inside the device fully automatically, with no effort required.

**1. Switch on the device:** Fill the water tank and press the on/off button.

**2. Start icemaking:** The IceBall is now ready for use and will start producing ice automatically.

**3. Eject the Ice Balls:** Once ice production is complete, the finished Ice Balls are automatically ejected. Pressing the 'Eject Ice Balls' button interrupts the current production cycle and ejects any Ice Balls that are not yet fully formed.

**4. Storage:** A custom-fit storage mould is available for the convenient storage of Ice Balls. It offers space for three Ice Balls and is ideal for temporary storage in the freezer.

---

ON / OFF BUTTON

---

EJECT ICE BALLS

---

CLEANING

---

ICEMAKING

---

CLEANING

---

LOW WATER LEVEL

---

ICE FULL



ICEMAKING

CLEANING

WATER

ICE FULL

### 01 PUMP SYSTEM

The pump system injects the water into the mould layer by layer at high pressure.

### 02 ALUMINUM MOULD

The precise aluminum mould produces perfect results and crystal-clear Ice Balls.



### 03 COOLING CIRCUIT

The key component is the compressor, which is also used in refrigerators.

### 04 INSULATION

The insulation ensures energy-efficient operation.

## The technology – here's how it works.

The technology behind the BEEZER® IceBall is based on the precise interaction of several components that work together to produce solid, crystal-clear Ice Balls. A key element is the powerful pump system that injects water into the aluminum mould in layers under high pressure. This multi-stage, controlled filling process minimises air pockets and enables the creation of a homogeneous Ice Ball structure, which is a decisive factor in the Ice Balls' exceptional clarity and purity.

Another important part of the technology is the precision-manufactured aluminum mould. The mould gives the Ice Balls their uniform, round shape, which is aesthetically pleasing and offers functional advantages.

A powerful yet quiet compressor provides the necessary cooling capacity. It forms part of a closed refrigeration cycle that ensures a constant temperature. The refrigerant R290 is used, which is efficient and energy-saving.

High-quality insulation reduces energy consumption to a minimum while keeping the cooling capacity stable.

### TECHNICAL DATA

- Refrigerant R290
- Climate class SN, N, ST, T
- 220-240 Volt, 177 W
- 50 Hz
- Ice production per cycle: 3 pieces (each Ø 63 mm)
- Max. ice storage capacity: 9 pieces (je 100 g)
- Water tank volume: 1.8 liters
- Ice cycle time: 75 Min. ice production + 15 min. defrosting
- TÜV-Süd/GS, protection class 1, CE
- Dimensions: Width 29.5 cm × Height 43.0 cm × Depth 46.5 cm
- Weight: 18.0 kg

Technical data subject to change without notice.

### ITEM-NO.

951.000 / 40 04822 95100 3



ENJOY IT ICE-COLD

## Ice Cubes. Anytime.

The BEEZER® IceCube mini provides Ice Cubes at the touch of a button, wherever you need them. It is compact, spontaneous and reliable.

Sometimes, a cool drink is needed immediately. A day on the balcony, a spontaneous visit, or an evening for two. No planning or preparation is required – just ice, exactly when you need it.

With the BEEZER® IceCube mini, every moment becomes an opportunity for real refreshment. This compact device produces fresh Ice Cubes in two sizes in just a few minutes, with no pre-cooling time or fixed connection required. As mobile as life itself. As intuitive as the touch of a button.

The IceCube mini delivers the perfect portion of ice quickly, hygienically and easily. For drinks that make an impression. For guests who stay. For effortless enjoyment.

## Overview

---

**26-27** ADVANTAGES & USP

---

DESIGN & OPERATION

---

**30-31** TECHNOLOGY & PRODUCT DETAILS



**BEEZER**  
a brand by ritter

❄️  
LARGE  
⏻

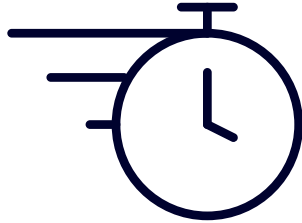

Ice Cubes in 8 minutes

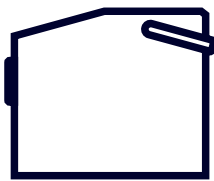

Compact & easy to carry

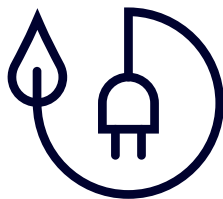

Quiet & efficient

BEEZER® IceCube mini

## Ice cold. Compact. Ready immediately.

The BEEZER® IceCube mini provides fresh ice whenever you need it, offering a smart solution for those who value spontaneity and don't want to wait around or deal with bulky cooling technology.

With a footprint barely larger than an A4 sheet of paper, the IceCube mini can be placed anywhere. In just 8-9 minutes, it produces eight fresh Ice Cubes in two sizes and can produce up to 12 kilograms of ice per day. So you're always well prepared.

The elegant touch panel makes operation intuitive. A water level warning and an automatic shut-off when the ice container is full ensure maximum convenience and safety. The integrated self-cleaning function guarantees hygienic cleanliness, making it particularly practical.



## Simple function and operation.

Making ice has never been easier than with the BEEZER® IceCube mini: simply press a button and your first fresh Ice Cubes will be ready in under ten minutes. Thanks to the intuitive touch controls and clear LED display, it is easy to use. Whether you want small or large Ice Cubes is entirely up to you.

**Ice full:** The light will come on when the ice container is full.

**Icemaking:** Ice production is in progress. The first cycle takes approx. 8–9 minutes.

**Low water level:** The light comes on when the water level is too low.

**SMALL = Small Ice Cubes:** Switches to producing small Ice Cubes.

**LARGE = Large Ice Cubes:** Selects the production of large Ice Cubes.

**On/Off Button:** Starts or stops ice production at the touch of a button.

**1. Prepare the appliance:** Open the lid and remove the ice container. Fill the water tank with fresh drinking water up to the ‚MAX‘ mark. Reinsert the ice container and close the lid.

**2. Switch on the appliance:** Press the on/off button. The ‚Ice making‘ indicator light will turn on.

**3. Select the desired Ice Cube size:** Production starts with large Ice Cubes by default. This can be changed using the ‚SMALL‘ or ‚LARGE‘ buttons.

**4. Remove ice:** When the Ice Cubes are ready, they are automatically pushed into the ice container. The appliance will stop automatically when the container is full.

---

ICE FULL

---

ICEMAKING

---

SIZE OF ICE CUBES

---

ON / OFF BUTTON



SMALL

LARGE



### 01 FAST PRODUCTION

The IceCube mini produces eight fresh Ice Cubes in just 8–9 minutes, making it ideal for when you need a quick refreshment.

### 02 PORTABLE WITH INTEGRATED HANDLE

Thanks to its integrated carrying handle, the IceCube mini is easy to transport and can be used anywhere.



### 03 COOLING CIRCUIT

The key component is the compressor, which is also used in refrigerators.

### 04 INSULATION

The insulation ensures energy-efficient operation.

## The technology – here's how it works.

The BEEZER® IceCube mini produces Ice Cubes using a powerful, compact refrigeration cycle with a compressor similar to those found in fridges. Once the integrated water tank has been filled, the compressor provides targeted cooling at the evaporator pins, where ice forms within a matter of minutes.

The housing is insulated to support energy-efficient operation by keeping the cold inside the device and minimising energy consumption. The sophisticated design with a carrying handle allows for mobile use, whether in the kitchen, on the balcony, or while camping.

The result is fast, reliable Ice Cube production in a compact format, with no need for a fixed connection and sophisticated cooling technology.

### TECHNICAL DATA

- Refrigerant R600a
- Climate class SN, N
- 220-240 Volt, 120 W
- 50 Hz, ≤50dB(A)
- Capacity: 11-12 kg/24h
- Water tank volume: 0.8 liters
- Ice Basket capacity: 0.9 liters
- Intertek/GS, protection class 1, CE
- Dimensions: Width 18.5 cm × Height 27.5 cm  
Depth 30.5 cm
- Weight: 5.6 kg

### ITEM-NO.

952.000 / 40 04822 95200 0



Technical data subject to change without notice.

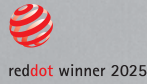

# BEEZER®

## a brand by ritter

Three devices. One promise:  
refreshing inspiration.

From perfectly chilled bottles in just a few minutes to crystal-clear Ice Balls and fresh Ice Cubes at the touch of a button, BEEZER® is all about stylish cooling technology that delivers an exceptional experience. Each product combines functionality, design and innovation to create impressive drinks. From the first moment to the last sip, BEEZER® delivers. **The art of cooling.**

### YOUR CONTACT PARTNERS

**Klaus Rehm**, Export Sales Manager  
 klaus.rehm@ritterwerk.de  
 Phone: +49 (8142) 440 16-28  
 Mobile: +49 (172) 823 91 52

**Lorin Schüller**, Sales Manager  
 lorin.schueller@ritterwerk.de  
 Phone: +49 (8142) 440 16-58  
 Mobile: +49 (176) 626 143 60

ritterwerk GmbH  
 Industriestraße 13  
 82194 Gröbenzell

info@ritterwerk.com  
 www.ritterwerk.com/BEEZER  
 Socials @myBEEZER

Phone: +49 (8142) 440 16-0  
 Fax: +49 (8142) 440 16-70



Dated 01/2026